

**ELECTRONIC CODE OF FEDERAL REGULATIONS**

e-CFR data is current as of November 23, 2016

Title 30 → Chapter I → Subchapter B → Part 7 → Subpart E

Title 30: Mineral Resources  
PART 7—TESTING BY APPLICANT OR THIRD PARTY**Subpart E—Diesel Engines Intended for Use in Underground Coal Mines****Contents**

- §7.81 Purpose and effective date.
- §7.82 Definitions.
- §7.83 Application requirements.
- §7.84 Technical requirements.
- §7.85 Critical characteristics.
- §7.86 Test equipment and specifications.
- §7.87 Test to determine the maximum fuel-air ratio.
- §7.88 Test to determine the gaseous ventilation rate.
- §7.89 Test to determine the particulate index.
- §7.90 Approval marking.
- §7.91 Post-approval product audit.
- §7.92 New technology.

SOURCE: 61 FR 55504, Oct. 25, 1996, unless otherwise noted.

[↑ Back to Top](#)**§7.81 Purpose and effective date.**

Subpart A general provisions of this part apply to this subpart E. Subpart E establishes the specific engine performance and exhaust emission requirements for MSHA approval of diesel engines for use in areas of underground coal mines where permissible electric equipment is required and areas where non-permissible electric equipment is allowed. It is effective November 25, 1996.

[↑ Back to Top](#)**§7.82 Definitions.**

In addition to subpart A definitions of this part, the following definitions apply in this subpart.

*Brake Power.* The observed power measured at the crankshaft or its equivalent when the engine is equipped only with standard auxiliaries necessary for its operation on the test bed.

*Category A engines.* Diesel engines intended for use in areas of underground coal mines where permissible electric equipment is required.

*Category B engines.* Diesel engines intended for use in areas of underground coal mines where nonpermissible electric equipment is allowed.

*Corrosion-resistant material.* Material that has at least the corrosion-resistant properties of type 304 stainless steel.

*Diesel engine.* Any compression ignition internal combustion engine using the basic diesel cycle where combustion results from the spraying of fuel into air heated by compression.

*Exhaust emission.* Any substance emitted to the atmosphere from the exhaust port of the combustion chamber of a diesel engine.

*Intermediate speed.* Maximum torque speed if it occurs between 60 percent and 75 percent of rated speed. If the maximum torque speed is less than 60 percent of rated speed, then the intermediate speed shall be 60 percent of the rated speed. If the maximum torque speed is greater than 75 percent of the rated speed, then the intermediate speed shall be 75 percent of rated speed.

*Low idle speed.* The minimum no load speed as specified by the engine manufacturer.

*Maximum torque speed.* The speed at which an engine develops maximum torque.

*Operational range.* All speed and load (including percent loads) combinations from the rated speed to the minimum permitted engine speed at full load as specified by the engine manufacturer.

*Particulates.* Any material collected on a specified filter medium after diluting exhaust gases with clean, filtered air at a temperature of less than or equal to 125 °F (52 °C), as measured at a point immediately upstream of the primary filter. This is primarily carbon, condensed hydrocarbons, sulfates, and associated water.

*Percent load.* The fraction of the maximum available torque at an engine speed.

*Rated horsepower.* The nominal brake power output of a diesel engine as specified by the engine manufacturer with a specified production tolerance. For laboratory test purposes, the fuel pump calibration for the rated horsepower must be set between the nominal and the maximum fuel tolerance specification.

*Rated speed.* Speed at which the rated power is delivered, as specified by the engine manufacturer.

*Steady-state condition.* Diesel engine operating condition which is at a constant speed and load and at stabilized temperatures and pressures.

*Total oxides of nitrogen.* The sum total of the measured parts per millions (ppm) of nitric oxide (NO) plus the measured ppm of nitrogen dioxide (NO<sub>2</sub>).

↑ Back to Top

### §7.83 Application requirements.

(a) An application for approval of a diesel engine shall contain sufficient information to document compliance with the technical requirements of this subpart and specify whether the application is for a category A engine or category B engine.

(b) The application shall include the following engine specifications—

- (1) Model number;
- (2) Number of cylinders, cylinder bore diameter, piston stroke, engine displacement;
- (3) Maximum recommended air inlet restriction and exhaust backpressure;
- (4) Rated speed(s), rated horsepower(s) at rated speed(s), maximum torque speed, maximum rated torque, high idle, minimum permitted engine speed at full load, low idle;
- (5) Fuel consumption at rated horsepower(s) and at the maximum rated torque;
- (6) Fuel injection timing; and
- (7) Performance specifications of turbocharger, if applicable.

(c) The application shall include dimensional drawings (including tolerances) of the following components specifying all details affecting the technical requirements of this subpart. Composite drawings specifying the required construction details may be submitted instead of individual drawings of the following components—

- (1) Cylinder head;
- (2) Piston;
- (3) Inlet valve;
- (4) Exhaust valve;
- (5) Cam shaft—profile;
- (6) Fuel cam shaft, if applicable;
- (7) Injector body;
- (8) Injector nozzle;
- (9) Injection fuel pump;
- (10) Governor;

- (11) Turbocharger, if applicable;
  - (12) Aftercooler, if applicable;
  - (13) Valve guide;
  - (14) Cylinder head gasket; and
  - (15) Precombustion chamber, if applicable.
- (d) The application shall include a drawing showing the general arrangement of the engine.
- (e) All drawings shall be titled, dated, numbered, and include the latest revision number.
- (f) When all necessary testing has been completed, the following information shall be submitted:
- (1) The gaseous ventilation rate for the rated speed and horsepower.
  - (2) The particulate index for the rated speed and horsepower.
  - (3) A fuel deration chart for altitudes for each rated speed and horsepower.

[↑ Back to Top](#)

**§7.84 Technical requirements.**

(a) *Fuel injection adjustment.* The fuel injection system of the engine shall be constructed so that the quantity of fuel injected can be controlled at a desired maximum value. This adjustment shall be changeable only after breaking a seal or by altering the design.

(b) *Maximum fuel-air ratio.* At the maximum fuel-air ratio determined by §7.87 of this part, the concentrations (by volume, dry basis) of carbon monoxide (CO) and oxides of nitrogen (NO<sub>x</sub>) in the undiluted exhaust gas shall not exceed the following:

- (1) There shall be no more than 0.30 percent CO and no more than 0.20 percent NO<sub>x</sub> for category A engines.
- (2) There shall be no more than 0.25 percent CO and no more than 0.20 percent NO<sub>x</sub> for category B engines.

(c) *Gaseous emissions ventilation rate.* Ventilation rates necessary to dilute gaseous exhaust emissions to the following values shall be determined under §7.88 of this part:

Carbon dioxide	-5000 ppm
Carbon monoxide	-50 ppm
Nitric oxide	-25 ppm
Nitrogen dioxide	-5 ppm

A gaseous ventilation rate shall be determined for each requested speed and horsepower rating as described in §7.88(b) of this part.

(d) *Fuel deration.* The fuel rates specified in the fuel deration chart shall be based on the tests conducted under paragraphs (b) and (c) of this section and shall ensure that the maximum fuel:air (f/a) ratio determined under paragraph (b) of this section is not exceeded at the altitudes specified in the fuel deration chart.

(e) *Particulate index.* For each rated speed and horsepower requested, the particulate index necessary to dilute the exhaust particulate emissions to 1 mg/m<sup>3</sup> shall be determined under §7.89 of this part.

[↑ Back to Top](#)

**§7.85 Critical characteristics.**

The following critical characteristics shall be inspected or tested on each diesel engine to which an approval marking is affixed—

- (a) Fuel rate is set properly; and
- (b) Fuel injection pump adjustment is sealed, if applicable.

[↑ Back to Top](#)

**§7.86 Test equipment and specifications.**

(a) Dynamometer test cell shall be used in determining the maximum f/a ratio, gaseous ventilation rates, and the particulate index.

(1) The following testing devices shall be provided:

(i) An apparatus for measuring torque that provides an accuracy of ±2.0 percent based on the engine's maximum value;

(ii) An apparatus for measuring revolutions per minute (rpm) that provides an accuracy of ±2.0 percent based on the engine's maximum value;

(iii) An apparatus for measuring temperature that provides an accuracy of ±4 °F (2 °C) of the absolute value except for the exhaust gas temperature device that provides an accuracy of ±27 °F (15 °C);

(iv) An apparatus for measuring intake and exhaust restriction pressures that provides an accuracy of ±5 percent of maximum;

(v) An apparatus for measuring atmospheric pressure that provides an accuracy of ±0.5 percent of reading;

(vi) An apparatus for measuring fuel flow that provides an accuracy of ±2 percent based on the engine's maximum value;

(vii) An apparatus for measuring the inlet air flow rate of the diesel engine that provides an accuracy of ±2 percent based on the engine's maximum value; and

(viii) For testing category A engines, an apparatus for metering in 1.0 ±0.1 percent, by volume, of methane (CH<sub>4</sub>) into the intake air system shall be provided.

(2) The test fuel specified in Table E-1 shall be a low volatile hydrocarbon fuel commercially designated as "Type 2-D" grade diesel fuel. The fuel may contain nonmetallic additives as follows: Cetane improver, metal deactivator, antioxidant, dehazer, antirust, pour depressant, dye, dispersant, and biocide.

**TABLE E-1—DIESEL TEST FUEL SPECIFICATIONS**

Item	ASTM	Type 2-D
Cetane number	D613	40-48
Cetane index	D976	40-48
Distillation range:		
IBP °F	D86	340-400
(°C)		(171.1-204.4)
10 pct. point, °F	D86	400-460
(°C)		(204.4-237.8)
50 pct. point, °F	D86	470-540
(°C)		(243.3-282.2)
90 pct. point, °F	D86	560-630
(°C)		(293.3-332.2)
EP, °F	D86	610-690
(°C)		(321.1-365.6)
Gravity, °API	D287	32-37
Total sulfur, pct.	D2622	0.03-0.05
Hydrocarbon composition:		
Aromatics, pct.	D1319	27 minimum
Paraffins, naphthenes, olefins	D1319	Remainder
Flashpoint, minimum, °F	93	130
(°C)		(54.4)
Viscosity, centistokes	445	2.0-3.2

(3) The test fuel temperature at the inlet to the diesel engine's fuel injection pump shall be controlled to the engine manufacturer's specification.

(4) The engine coolant temperature (if applicable) shall be maintained at normal operating temperatures as specified by the engine manufacturer.

(5) The charge air temperature and cooler pressure drop (if applicable) shall be set to within ±7 °F(4 °C) and ±0.59 inches Hg (2kPa) respectively, of the manufacturer's specification.

(b) Gaseous emission sampling system shall be used in determining the gaseous ventilation rates.

(1) The schematic of the gaseous sampling system shown in Figure E-1 shall be used for testing category A engines. Various configurations of Figure E-1 may produce equivalent results. The components in Figure E-1 are designated as follows—

- (i) Filters—F1, F2, F3, and F4;
  - (ii) Flowmeters—FL1, FL2, FL3, FL4, FL5, FL6, and FL7;
  - (iii) Upstream Gauges—G1, G2, and G5;
  - (iv) Downstream Gauges—G3, G4, and G6;
  - (v) Pressure Gauges—P1, P2, P3, P4, P5, and P6;
  - (vi) Regulators—R1, R2, R3, R4, R5, R6, and R7;
  - (vii) Selector Valves—V1, V2, V3, V4, V6, V7, V8, V15, and V19;
  - (viii) Heated Selector Valves—V5, V13, V16, and V17;
  - (ix) Flow Control Valves—V9, V10, V11 and V12;
  - (x) Heated Flow Control Valves—V14 and V18;
  - (xi) Pump—Sample Transfer Pump;
  - (xii) Temperature Sensor—(T1);
  - (xiii) Dryer—D1 and D2; and
  - (xiv) Water traps—WT1 and WT2.
- (A) Water removal from the sample shall be done by condensation.
- (B) The sample gas temperature or dew point shall be monitored either within the water trap or downstream of the water trap and shall not exceed 45 °F (7 °C).
- (C) Chemical dryers are not permitted.

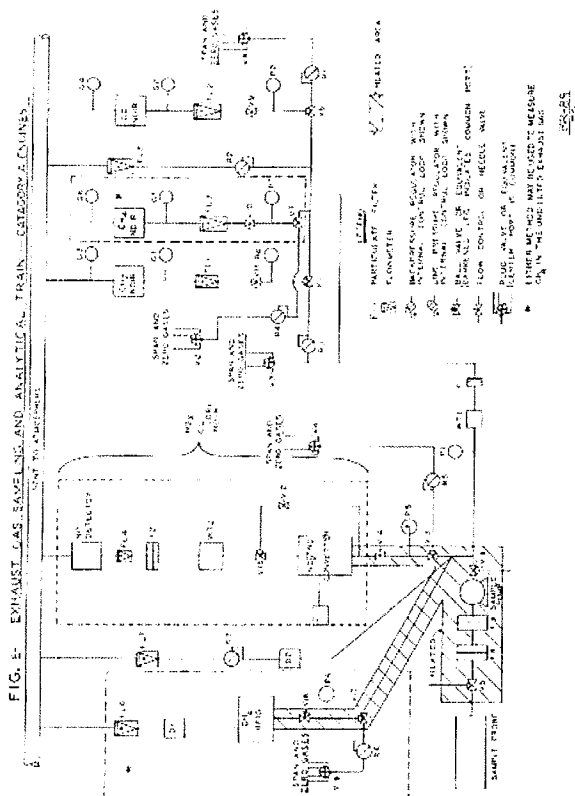

[View or download PDF](#)

(2) The schematic of the gaseous sampling system shown in Figure E-2 shall be used for testing category B engines. Various configurations of Figure E-2 may produce equivalent results. The components are designated as follows—

- (i) Filters—F1, F2, F3, and F4;
- (ii) Flowmeters—FL1, FL2, FL3, and FL4;
- (iii) Upstream Gauges—G1, and G2;
- (iv) Downstream Gauges—G3, and G4;
- (v) Pressure Gauges—P1, P2, P3, and P4;
- (vi) Regulators—R1, R2, R3, and R4;
- (vii) Selector Valves—V1, V2, V3, V4, V6, and V7;
- (viii) Heated Selector Valves—V5, V8, and V12;
- (ix) Flow Control Valves—V9, V10, V11;
- (x) Heated Flow Control Valves—V13;
- (xi) Pump—Sample Transfer Pump;
- (xii) Temperature Sensor—(T1); and
- (xiii) Water traps—WT1 and WT2.

(A) Water removal from the sample shall be done by condensation.

(B) The sample gas temperature or dew point shall be monitored either within the water trap or downstream of the water trap and shall not exceed 45 °F (7 °C).

(C) Chemical dryers are not permitted.

(3) All components or parts of components that are in contact with the sample gas or corrosive calibration gases shall be corrosion-resistant material.

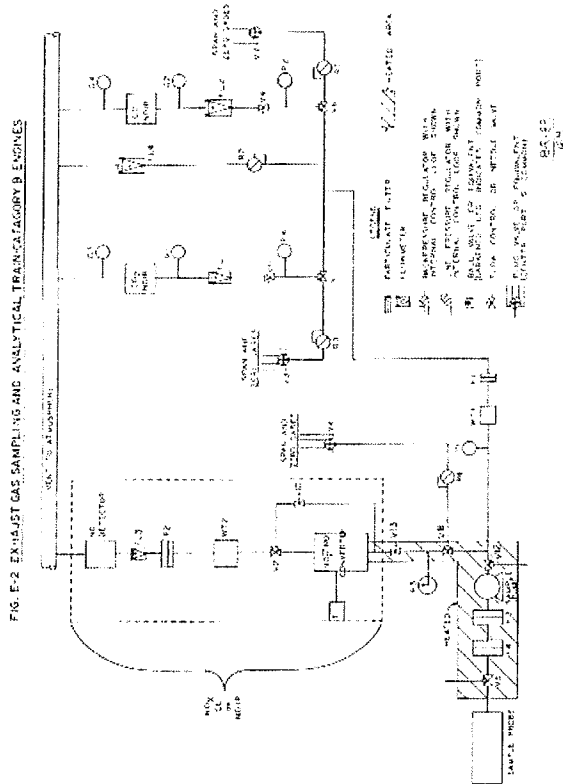

[View or download PDF](#)

(4) All analyzers shall obtain the sample to be analyzed from the same sample probe.

- (5) CO and CO<sub>2</sub> measurements shall be made on a dry basis.
- (6) Calibration or span gases for the NO<sub>x</sub> measurement system shall pass through the NO<sub>2</sub> to NO converter.
- (7) A stainless steel sample probe shall be straight, closed-end, multi-holed, and shall be placed inside the exhaust pipe.
- (i) The probe length shall be at least 80 percent of the diameter of the exhaust pipe.
- (ii) The inside diameter of the sample probe shall not be greater than the inside diameter of the sample line.
- (iii) The heated sample line shall have a 0.197 inch (5 mm) minimum and a 0.53 inch (13.5 mm) maximum inside diameter.
- (iv) The wall thickness of the probe shall not be greater than 0.040 inch (1 mm).
- (v) There shall be a minimum of 3 holes in 3 different radial planes sized to sample approximately the same flow.
- (8) The sample probe shall be located in the exhaust pipe at a minimum distance of 1.6 feet (0.5 meters) or 3 times the diameter of the exhaust pipe, whichever is the larger, from the exhaust manifold outlet flange or the outlet of the turbocharger. The exhaust gas temperature at the sample probe shall be a minimum of 158 °F (70 °C).
- (9) The maximum allowable leakage rate on the vacuum side of the analyzer pump shall be 0.5 percent of the in-use flow rate for the portion of the system being checked.
- (10) *General analyzer specifications.* (i) The total measurement error, including the cross sensitivity to other gases, (paragraphs (b)(11)(ii), (b)(12)(iii), (b)(13)(iii), and (b)(13)(iv) of this section), shall not exceed ±5 percent of the reading or ±3.5 percent of full scale, whichever is smaller. For concentrations of less than 100 ppm the measurement error shall not exceed ±4 ppm.
- (ii) The repeatability, defined as 2.5 times the standard deviation of 10 repetitive responses to a given calibration or span gas, must be no greater than ±1 percent of full scale concentration for each range used above 155 parts per million (ppm) or parts per million equivalent carbon (ppmC) or ±2 percent of each range used below 155 ppm (or ppmC).
- (iii) The analyzer peak to peak response to zero and calibration or span gases over any 10 second period shall not exceed 2 percent of full scale on all ranges used.
- (iv) The analyzer zero drift during a 1-hour period shall be less than 2 percent of full scale on the lowest range used. The zero-response is the mean response, including noise, to a zero gas during a 30-second time interval.
- (v) The analyzer span drift during a 1-hour period shall be less than 2 percent of full scale on the lowest range used. The analyzer span is defined as the difference between the span response and the zero response. The span response is the mean response, including noise, to a span gas during a 30-second time interval.
- (11) *CO and CO<sub>2</sub> analyzer specifications.* (i) Measurements shall be made with nondispersive infrared (NDIR) analyzers.
- (ii) For the CO analyzer, the water and CO<sub>2</sub> interference shall be less than 1 percent of full scale for ranges equal to or greater than 300 ppm (3 ppm for ranges below 300 ppm) when a CO<sub>2</sub> span gas concentration of 80 percent to 100 percent of full scale of the maximum operating range used during testing is bubbled through water at room temperature.
- (12) For NO<sub>x</sub> analysis using a chemiluminescence (CL) analyzer the following parameters shall apply:
- (i) From the sample point to the NO<sub>2</sub> to NO converter, the NO<sub>x</sub> sample shall be maintained between 131 °F (55 °C) and 392 °F (200 °C).
- (ii) The NO<sub>2</sub> to NO converter efficiency shall be at least 90 percent.
- (iii) The quench interference from CO<sub>2</sub> and water vapor must be less than 3.0 percent.
- (13) For NO<sub>x</sub> analysis using an NDIR analyzer system the following parameters shall apply:
- (i) The system shall include a NO<sub>2</sub> to NO converter, a water trap, and a NDIR analyzer.
- (ii) From the sample point to the NO<sub>2</sub> to NO converter, the NO<sub>x</sub> sample shall be maintained between 131 °F (55 °C) and 392 °F (200 °C).
- (iii) The minimum water rejection ratio (maximum water interference) for the NO<sub>x</sub> NDIR analyzer shall be 5,000:1.
- (iv) The minimum CO<sub>2</sub> rejection ratio (maximum CO<sub>2</sub> interference) for the NO<sub>x</sub> NDIR analyzer shall be 30,000:1.

(14) When CH<sub>4</sub> is measured using a heated flame ionization detector (HFID) the following shall apply:

(i) The analyzer shall be equipped with a constant temperature oven that houses the detector and sample-handling components.

(ii) The detector, oven, and sample-handling components shall be suitable for continuous operation at temperatures of 374 °F (190 °C) ±18 °F (10 °C).

(iii) The analyzer fuel shall contain 40 ±2 percent hydrogen. The balance shall be helium. The mixture shall contain ≤1 part per million equivalent carbon (ppmC), and ≤400 ppm CO.

(iv) The burner air shall contain <2 ppmC hydrocarbon.

(v) The percent of oxygen interference shall be less than 5 percent.

(15) An NDIR analyzer for measuring CH<sub>4</sub> may be used in place of the HFID specified in paragraph (b)(14) of this section and shall conform to the requirements of paragraph (b)(10) of this section. Methane measurements shall be made on a dry basis.

(16) Calibration gas values shall be traceable to the National Institute for Standards and Testing (NIST), "Standard Reference Materials" (SRM's). The analytical accuracy of the calibration gas values shall be within 2.0 percent of NIST gas standards.

(17) Span gas values shall be traceable to NIST SRM's. The analytical accuracy of the span gas values shall be within 2.0 percent of NIST gas standards.

(18) Calibration or span gases for the CO and CO<sub>2</sub> analyzers shall have purified nitrogen as a diluent. Calibration or span gases for the CH<sub>4</sub> analyzer shall be CH<sub>4</sub> with purified synthetic air or purified nitrogen as diluent.

(19) Calibration or span gases for the NO<sub>x</sub> analyzer shall be NO with a maximum NO<sub>2</sub> concentration of 5 percent of the NO content. Purified nitrogen shall be the diluent.

(20) Zero-grade gases for the CO, CO<sub>2</sub>, CH<sub>4</sub>, and NO<sub>x</sub> analyzers shall be either purified synthetic air or purified nitrogen.

(21) The allowable zero-grade gas (purified synthetic air or purified nitrogen) impurity concentrations shall not exceed ≤1ppm C, ≤1 ppm CO, ≤400 ppm CO<sub>2</sub>, and ≤0.1 ppm NO.

(22) The calibration and span gases may also be obtained by means of a gas divider. The accuracy of the mixing device must be such that the concentration of the diluted calibration gases are within 2 percent.

(c) Particulate sampling system shall be used in determining the particulate index. A schematic of a full flow (single dilution) particulate sampling system for testing under this subpart is shown in Figures E-3 and E-4.

(1) The dilution system shall meet the following parameters:

(i) Either a positive displacement pump (PDP) or a critical flow venturi (CFV) shall be used as the pump/mass measurement device shown in Figure E-3.

(ii) The total volume of the mixture of exhaust and dilution air shall be measured.

(iii) All parts of the system from the exhaust pipe up to the filter holder, which are in contact with raw and diluted exhaust gas, shall be designed to minimize deposition or alteration of the particulate.

(iv) All parts shall be made of electrically conductive materials that do not react with exhaust gas components.

(v) All parts shall be electrically grounded to prevent electrostatic effects.

(vi) Systems other than full flow systems may also be used provided they yield equivalent results where:

(A) A seven sample pair (or larger) correlation study between the system under consideration and a full flow dilution system shall be run concurrently.

(B) Correlation testing is to be performed at the same laboratory, test cell, and on the same engine.

(C) The equivalency criterion is defined as a ±5 percent agreement of the sample pair averages.

(2) The mass of particulate in the exhaust shall be collected by filtration. The exhaust temperature immediately before the primary particulate filter shall not exceed 125 °F (52.0 °C).



(3) Exhaust system backpressure shall not be artificially lowered by the PDP, CFV systems or dilution air inlet system. Static exhaust backpressure measured with the PDP or CFV system operating shall remain within  $\pm 0.44$  inches Hg (1.5 kPa) of the static pressure measured without being connected to the PDP or CFV at identical engine speed and load.

(4) The gas mixture temperature shall be measured at a point immediately ahead of the pump or mass measurement device.

(i) Using PDP, the gas mixture temperature shall be maintained within  $\pm 10$  °F (6.0 °C) of the average operating temperature observed during the test, when no flow compensation is used.

(ii) Flow compensation can be used provided that the temperature at the inlet to the PDP does not exceed 122 °F (50 °C).

(iii) Using CFV, the gas mixture temperature shall be maintained within  $\pm 20$  °F (11 °C) of the average operating temperature observed during the test, when no flow compensation is used.

(5) The heat exchanger shall be of sufficient capacity to maintain the temperature within the limits required above and is optional if electronic flow compensation is used.

(6) When the temperature at the inlet of either the PDP or CFV exceeds the limits stated in either paragraphs (c)(4)(i) or (c)(4)(iii) of this section, an electronic flow compensation system shall be required for continuous measurement of the flow rate and control of the proportional sampling in the particulate sampling system.

(7) The flow capacity of the system shall be large enough to eliminate water condensation.

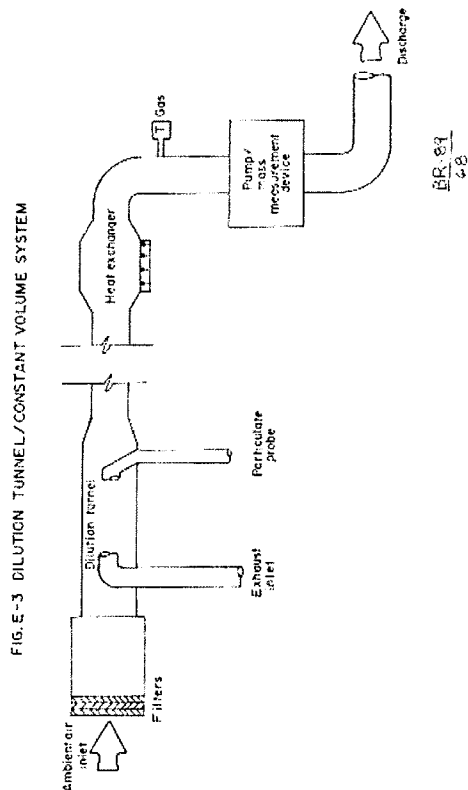

[View or download PDF](#)

FIG. E-4. PARTICULATE SAMPLING SYSTEM.

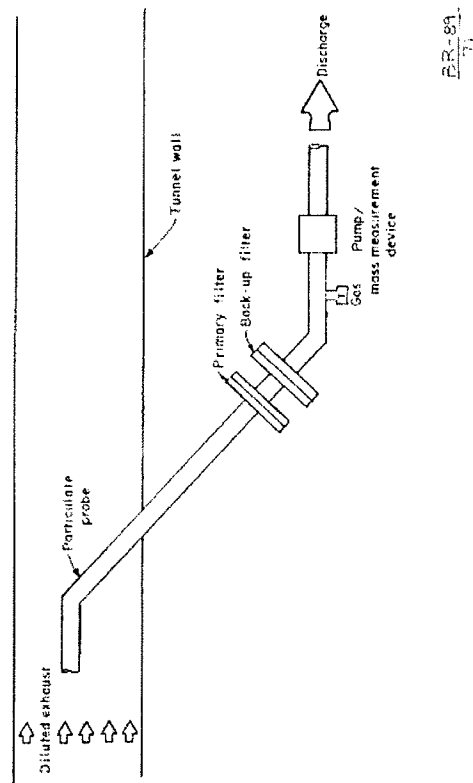

View or download PDF

(8) The flow capacity of the PDP or CFV system using single dilution shall maintain the diluted exhaust at 125 °F (52.0 °C) or less immediately before the primary particulate filter.

(9) The flow capacity of the PDP or CFV system using a double dilution system shall be sufficient to maintain the diluted exhaust in the dilution tunnel at 375 °F (191 °C) or less at the sampling zone.

(10) The secondary dilution system shall provide sufficient secondary dilution air to maintain the double-diluted exhaust stream at 125 °F (52.0 °C) or less immediately before the primary particulate filter.

(11) The gas flow meters or the mass flow measurement instrumentation shall have a maximum error of the measured value within  $\pm 2$  percent of reading.

(12) The dilution air shall have a temperature of 77 °F  $\pm 9$  °F (25 °C  $\pm 5$  °C), and be—

- (i) Filtered at the air inlet; or
- (ii) Sampled to determine background particulate levels, which can then be subtracted from the values measured in the exhaust stream.

(13) The dilution tunnel shall have the following specifications:

- (i) Be small enough in diameter to cause turbulent flow (Reynolds number greater than 4,000) and of sufficient length to cause complete mixing of the exhaust and dilution air;
- (ii) Be at least 3 inches (75 mm) in diameter; and
- (iii) Be configured to direct the engine exhaust downstream at the point where it is introduced into the dilution tunnel for thorough mixing.

(14) The exhaust pipe length from the exit of the engine exhaust manifold or turbocharger outlet to the dilution tunnel shall not exceed a total length of 32 feet (10 m).

(i) When the exhaust pipe exceeds 12 feet (4 m), then all pipe in excess of 12 feet (4 m) shall be insulated with a radial thickness of at least 1.0 inch (25 mm) and the thermal conductivity of the insulating material shall be no greater than 0.1 W/mK measured at 752 °F (400 °C).

(ii) To reduce the thermal inertia of the exhaust pipe, the thickness to diameter ratio shall be 0.015 or less.

(iii) The use of flexible sections shall be limited to the length to diameter ratio of 12 or less.

(15) The particulate sample probe shall—

(i) Be installed in the dilution tunnel facing upstream, on the dilution tunnel centerline, and approximately 10 dilution tunnel diameters downstream of the point where the engine's exhaust enters the dilution tunnel; and

(ii) Have 0.5 inches (12 mm) minimum inside diameter.

(16) The inlet gas temperature to the particulate sample pump or mass measurement device shall remain a constant temperature of  $\pm 5$  °F (3.0 °C) if flow compensation is not used.

(17) The secondary dilution portion of the double dilution system shall have:

(i) A particulate transfer tube shall have a 0.5 inch (12 mm) minimum inside diameter not to exceed 40 inches (1020 mm) in length measured from the probe tip to the secondary dilution tunnel has:

(A) An inlet with the transfer tube facing upstream in the primary dilution tunnel, centerline, and approximately 10 dilution tunnel diameters downstream of the point where the engine's exhaust enters the dilution tunnel.

(B) An outlet where the transfer tube exits on the centerline of the secondary tunnel and points downstream.

(ii) A secondary tunnel that has a minimum diameter of 3.0 inches (75 mm), and of sufficient length to provide a residence time of at least 0.25 seconds for the double-diluted sample.

(iii) Secondary dilution air supplied at a temperature of 77 °F  $\pm$  9 °F (25 °C  $\pm$  5 °C).

(iv) A primary filter holder located within 12.0 inches (300 mm) of the exit of the secondary tunnel.

(18) The particulate sampling filters shall—

(i) Be fluorocarbon-coated glass fiber filters or fluorocarbon-based (membrane) filters and have a 0.3  $\mu$ m di-octylphthalate (DOP) collection efficiency of at least 95 percent at a gas face velocity between 35 and 80 cm/s.;

(ii) Have a minimum diameter of 1.85 inches (47 mm), 1.46 inches (37 mm) stain diameter;

(iii) Have a minimum filter loading ratio of 0.5mg/1075 mm<sup>2</sup> stain area for the single filter method.

(iv) Have minimum filter loading such that the sum of all eight (8) multiple filters is equal to the minimum loading value (mg) for a single filter multiplied by the square root of eight (8).

(v) Be sampled at the same time by a pair of filters in series (one primary and one backup filter) so that:

(A) The backup filter holder shall be located no more than 4 inches (100 mm) downstream of the primary filter holder.

(B) The primary and backup filters shall not be in contact with each other.

(C) The filters may be weighed separately or as a pair with the filters placed stain side to stain side.

(D) The single filter method incorporates a bypass system for passing the sample through the filters at the desired time.

(vi) Have a pressure drop increase between the beginning and end of the test of no more than 7.4 in Hg (25kPa).

(vii) Filters of identical quality shall be used when performing correlation tests specified in paragraph (c)(1)(vi) of this section.

(19) *Weighing chamber specifications.* (i) The temperature of the chamber (room) in which the particulate filters are conditioned and weighed shall be maintained to within 72 °F  $\pm$  5 °F (22 °C  $\pm$  3 °C) during all filter conditioning and weighing.

(ii) The humidity of the chamber (room) in which the particulate filters are conditioned and weighed shall be maintained to a dewpoint of 49 °F  $\pm$  5 °F (9.5 °C  $\pm$  3 °C) and a relative humidity of 45 percent  $\pm$  8 percent during all filter conditioning and weighing.

(iii) The chamber (room) environment shall be free of any ambient contaminants (such as dust) that would settle on the particulate filters during their stabilization. This shall be determined as follows:

(A) At least two unused reference filters or reference filter pairs shall be weighed within four (4) hours of, but preferably at the same time as the sample filter (pair) weighings.

(B) The reference filters are to be the same size and material as the sample filters.

(C) If the average weight of reference filters (reference filter pairs) changes between sample filter weighings by more than  $\pm 5.0$  percent ( $\pm 7.5$  percent for the filter pair respectively) of the recommended minimum filter loading in paragraphs (c)(18)(iii) or (c)(18)(iv) of this section, then all sample filters shall be discarded and the tests repeated.

(20) The analytical balance used to determine the weights of all filters shall have a precision (standard deviation) of  $20 \mu\text{g}$  and resolution of  $10 \mu\text{g}$ . For filters less than 70 mm diameter, the precision and resolution shall be  $2 \mu\text{g}$  and  $1 \mu\text{g}$ , respectively.

(21) All filters shall be neutralized to eliminate the effects of static electricity prior to weighing.

⤴ Back to Top

#### §7.87 Test to determine the maximum fuel-air ratio.

(a) *Test procedure.* (1) Couple the diesel engine to the dynamometer and connect the sampling and measurement devices specified in §7.86.

(2) Prior to testing, zero and span the CO and NO<sub>x</sub> analyzers to the lowest analyzer range that will be used during this test.

(3) While running the engine, the following shall apply:

(i) The parameter for the laboratory atmospheric factor,  $f_a$ , shall be:  $0.98 \leq f_a \leq 1.02$ ;

(A) The equation is  $f_a = (99/P_s) * ((T_a + 273)/298)^{0.7}$  for a naturally aspirated and mechanically supercharged engines; or

(B) The equation is  $f_a = (99/P_s)^{0.7} * ((T_a + 273)/298)^{1.5}$  for a turbocharged engine with or without cooling of the intake air.

Where:

$P_s$  = dry atmospheric pressure (kPa)

$T_a$  = intake air temperature (°C)

(ii) The air inlet restriction shall be set within  $\pm 10$  percent of the recommended maximum air inlet restriction as specified by the engine manufacturer at the engine operating condition giving maximum air flow to determine the concentration of CO as specified in paragraph (a)(6) of this section.

(iii) The exhaust backpressure restriction shall be set within  $\pm 10$  percent of the maximum exhaust backpressure as specified by the engine manufacturer at the engine operating condition giving maximum rated horsepower to determine the concentrations of CO and NO<sub>x</sub> as specified in paragraph (a)(6) of this section.

(iv) The air inlet restriction shall be set within  $\pm 10$  percent of a recommended clean air filter at the engine operating condition giving maximum air flow as specified by the engine manufacturer to determine the concentration of NO<sub>x</sub> as specified in paragraph (a)(6) of this section.

(4) The engine shall be at a steady-state condition when the exhaust gas samples are collected and other test data is measured.

(5) In a category A engine,  $1.0 \pm 0.1$  percent CH<sub>4</sub> shall be injected into the engine's intake air.

(6) Operate the engine at several speed/torque conditions to determine the concentrations of CO and NO<sub>x</sub>, dry basis, in the raw exhaust.

(b) *Acceptable performance.* The CO and NO<sub>x</sub> concentrations in the raw exhaust shall not exceed the limits specified in §7.84(b) throughout the specified operational range of the engine.

⤴ Back to Top

#### §7.88 Test to determine the gaseous ventilation rate.

The test shall be performed in the order listed in Table E-2. The test for determination of the particulate index described in §7.89 may be done simultaneously with this test.

(a) *Test procedure.* (1) Couple the diesel engine to the dynamometer and attach the sampling and measurement devices specified in §7.86.

(2) A minimum time of 10 minutes is required for each test mode.

- (3) CO, CO<sub>2</sub>, NO<sub>x</sub>, and CH<sub>4</sub> analyzers shall be zeroed and spanned at the analyzer range to be used prior to testing.
- (4) Run the engine.
  - (i) The parameter for  $f_a$  shall be calculated in accordance with §7.87(a)(3).
  - (ii) The air inlet and exhaust backpressure restrictions on the engine shall be set as specified in §§7.87(a)(3) (iii) and (iv).
- (5) The engine shall be at a steady-state condition before starting the test modes.
  - (i) The output from the gas analyzers shall be measured and recorded with exhaust gas flowing through the analyzers a minimum of the last three (3) minutes of each mode.
  - (ii) To evaluate the gaseous emissions, the last 60 seconds of each mode shall be averaged.
  - (iii) A 1.0 ±0.1 percent CH<sub>4</sub>, by volume, shall be injected into the engine's intake air for category A engines.
  - (iv) The engine speed and torque shall be measured and recorded at each test mode.
  - (v) The data required for use in the gaseous ventilation calculations specified in paragraph (a)(9) of this section shall be measured and recorded at each test mode.
- (6) Operate the engine at each rated speed and horsepower rating requested by the applicant according to Table E-2 in order to measure the raw exhaust gas concentration, dry basis, of CO, CO<sub>2</sub>, NO, and NO<sub>2</sub>, and CH<sub>4</sub>- exhaust (category A engines only).
  - (i) Test speeds shall be maintained within ±1 percent of rated speed or ±3 RPM, which ever is greater, except for low idle which shall be within the tolerances established by the manufacturer.
  - (ii) The specified torque shall be held so that the average over the period during which the measurements are taken is within ±2 percent of the maximum torque at the test speed.
- (7) The concentration of CH<sub>4</sub> in the intake air shall be measured for category A engines.

**TABLE E-2—GASEOUS TEST MODES**

Speed	Rated speed			Intermediate speed			Low-idle speed
% Torque	100	75	50	100	75	50	0

- (8) After completion of the test modes, the following shall be done:
  - (i) Zero and span the analyzers at the ranges used during the test.
  - (ii) The gaseous emission test shall be acceptable if the difference in the zero and span results taken before the test and after the test are less than 2 percent.
- (9) The gaseous ventilation rate for each exhaust gas contaminant shall be calculated as follows—
  - (i) The following abbreviations shall apply to both category A and category B engine calculations as appropriate:

- cfm—Cubic feet per min (ft<sup>3</sup>/min)
- Exh—Exhaust
- A—Air (lbs/hr)
- H—Grains of water per lb. of dry intake air
- J—Conversion factor
- m—Mass flow rate (mass/hr)
- TI—Intake air temperature (°F)
- PCAir—Percent Air
- PCCH<sub>4</sub>—Percent CH<sub>4</sub> (intake air)
- UCH<sub>4</sub>—Unburned CH<sub>4</sub>
- PCECH<sub>4</sub>—Percent Exhaust CH<sub>4</sub>

(ii) Exhaust gas flow calculation for category B engines shall be  $(m \text{ Exh}) = (A) + (m \text{ fuel})$ .

(iii) Fuel/air ratio for category B engines shall be  $(f/a) = (m \text{ fuel}) / (A)$ .

(iv) Methane flow through category A engines shall be determined by the following:

$$PC_{\text{Air}} = 100 - PC_{\text{CH}_4}$$

$$Y = (PC_{\text{Air}})(0.289) + (PC_{\text{CH}_4})(0.16)$$

$$Z = (0.16)(PC_{\text{CH}_4}) + Y$$

$$m_{\text{CH}_4} = (A)(Z) + (1 - Z)$$

(v) Exhaust gas flow calculation for category A engines shall be  $(m \text{ Exh}) = (A) + (m \text{ fuel}) + (m \text{ CH}_4)$

(vi) Unburned  $\text{CH}_4$  (lbs/hr) calculation for category A engines shall be  $m_{\text{UCH}_4} = (m \text{ Exh})(0.0052)(PC_{\text{ECH}_4})$

(vii) Fuel/air ratio for category A engines shall be  $(f/a) = ((m \text{ fuel}) + (m \text{ CH}_4) - (m \text{ UCH}_4)) \div (A)$

(viii) Conversion from dry to wet basis for both category A and category B engines shall be:

$$(\text{NO wet basis}) = (\text{NO dry basis})(J)$$

$$(\text{NO}_2 \text{ wet basis}) = (\text{NO}_2 \text{ dry basis})(J)$$

$$(\text{CO}_2 \text{ wet basis}) = (\text{CO}_2 \text{ dry basis})(J)$$

$$(\text{CO wet basis}) = (\text{CO dry basis})(10^{-4})(J)$$

Where:

$$J = (f/a)(-1.87) + (1 - (0.00022)(H))$$

(ix) NO and  $\text{NO}_2$  correction for humidity and temperature for category A and category B engines shall be:

$$(\text{NO corr}) = (\text{NO wet basis}) \div (E)$$

$$(\text{NO}_2 \text{ corr}) = (\text{NO}_2 \text{ wet basis}) \div (E)$$

Where:

$$E = 1.0 + (R)(H - 75) + (G)(Tl - 77)$$

$$R = (f/a)(0.044) - (0.0038)$$

$$G = (f/a)(-0.116) + (0.0053)$$

(x) The calculations to determine the m of each exhaust gas contaminant in grams per hour at each test point shall be as follows for category A and category B engines:

$$(m \text{ NO}) = (\text{NO corr})(0.000470)(m \text{ Exh})$$

$$(m \text{ NO}_2) = (\text{NO}_2 \text{ corr})(0.000720)(m \text{ Exh})$$

$$(m \text{ CO}_2) = (\text{CO}_2 \text{ wet basis})(6.89)(m \text{ Exh})$$

$$(m \text{ CO}) = (\text{CO wet basis})(4.38)(m \text{ Exh})$$

(xi) The calculations to determine the ventilation rate for each exhaust gas contaminant at each test point shall be as follows for category A and category B engines:

$$(\text{cfm NO}) = (m \text{ NO})(K)$$

$$(\text{cfm NO}_2) = (m \text{ NO}_2)(K)$$

$$(\text{cfm CO}_2) = (m \text{ CO}_2)(K)$$

$$(\text{cfm CO}) = (m \text{ CO})(K)$$

Where:

$$K = 13,913.4 / (\text{pollutant grams/mole}) (\text{pollutant dilution value specified in } \S 7.84(c)).$$

(b) The gaseous ventilation rate for each requested rated speed and horsepower shall be the highest ventilation rate calculated in paragraph (a)(9)(xi) of this section.

(1) Ventilation rates less than 20,000 cfm shall be rounded up to the next 500 cfm.

Example: 10,432 cfm shall be listed 10,500 cfm.

(2) Ventilation rates greater than 20,000 cfm shall be rounded up to the next 1,000 cfm.

Example: 26,382 cfm shall be listed 27,000 cfm.

[61 FR 55504, Oct. 25, 1996; 62 FR 34640, June 27, 1997]

† Back to Top

**§7.89 Test to determine the particulate index.**

The test shall be performed in the order listed in Table E-3.

(a) *Test procedure.* (1) Couple the diesel engine to the dynamometer and connect the sampling and measurement devices specified in §7.86.

(2) A minimum time of 10 minutes is required for each measuring point.

(3) Prior to testing, condition and weigh the particulate filters as follows:

(i) At least 1 hour before the test, each filter (pair) shall be placed in a closed, but unsealed, petri dish and placed in a weighing chamber (room) for stabilization.

(ii) At the end of the stabilization period, each filter (pair) shall be weighed. The reading is the tare weight.

(iii) The filter (pair) shall then be stored in a closed petri dish or a filter holder, both of which shall remain in the weighing chamber (room) until needed for testing.

(iv) The filter (pair) must be re-weighed if not used within 8 hours of its removal from the weighing chamber (room).

(4) Run the engine.

(i) The parameter for  $f_a$  shall be calculated in accordance with §7.87(a)(3).

(ii) The air inlet and exhaust backpressure restrictions on the engine shall be set as specified in §§7.87(a)(3) (iii) and (iv).

(iii) The dilution air shall be set to obtain a maximum filter face temperature of 125 °F (52 °C) or less at each test mode.

(iv) The total dilution ratio shall not be less than 4.

(5) The engine shall be at a steady state condition before starting the test modes.

(i) The engine speed and torque shall be measured and recorded at each test mode.

(ii) The data required for use in the particulate index calculation specified in paragraph (a)(9) of this section shall be measured and recorded at each test mode.

(6) A 1.0 ±0.1 percent CH<sub>4</sub>, by volume shall be injected into the engine's intake air for category A engines.

(7) Operate the engine at each rated speed and horsepower rating requested by the applicant according to Table E-3 to collect particulate on the primary filter.

(i) One pair of single filters shall be collected or eight multiple filter pairs shall be collected.

(ii) Particulate sampling shall be started after the engine has reached a steady-state condition.

(iii) The sampling time required per mode shall be either a minimum of 20 seconds for the single filter method or a minimum of 60 seconds for the multiple filter method.

(iv) The minimum particulate loading specified in §§7.86(c)(18) (iii) or (iv) shall be done.

**TABLE E-3—PARTICULATE TEST MODES**

Speed	Rated speed				Intermediate speed			Low-idle speed
	100	75	50	10	100	75	50	0
% Torque								
Weighting factor	0.15	0.15	0.15	0.1	0.1	0.1	0.1	0.15

(v) Test speeds shall be maintained within  $\pm$ percent of rated speed or  $\pm 3$  RPM, whichever is greater, except for low idle which shall be within the tolerances set by the manufacturer.

(vi) The specified torque shall be held so that the average over the period during which the measurements are being taken is within  $\pm 2$  percent of the maximum torque at the test speed.

(vii) The modal weighting factors (WF) given in Table E-3 shall be applied to the multiple filter method during the calculations as shown in paragraph (a)(9)(iii)(B) of this section.

(viii) For the single filter method, the modal WF shall be taken into account during sampling by taking a sample proportional to the exhaust mass flow for each mode of the cycle.

(8) After completion of the test, condition and weigh the particulate filters in the weighing chamber (room) as follows:

(i) Condition the filters for at least 1 hour, but not more than 80 hours.

(ii) At the end of the stabilization period, weigh each filter. The reading is the gross weight.

(iii) The particulate mass of each filter is its gross weight minus its tare weight.

(iv) The particulate mass ( $P_F$  for the single filter method;  $P_{F,i}$  for the multiple filter method) is the sum of the particulate masses collected on the primary and back-up filters.

(v) The test is void and must be rerun if the sample on the filter contacts the petri dish or any other surface.

(9) The particulate index for the mass particulate shall be calculated from the equations listed below—

(i) The following abbreviations shall be:

cfm—Cubic feet per min ( $\text{ft}^3 \text{ min}$ )

PT—Particulate (gr/hr)

$m_{\text{mix}}$ —Diluted exhaust gas mass flow rate on wet basis (kg/hr)

$m_{\text{sample}}$ —Mass of the diluted exhaust sample passed through the particulate sampling filters (kg)

$P_i$ —Particulate sample mass collected on a filter (mg) at each test mode as determined in Table E-3.

$K_p$ —Humidity correction factor for particulate

WF—Weighting factor

$i$ —Subscript denoting an individual mode,  $i = 1, \dots, n$

PI—Particulate Index (cfm)

(ii) When calculating ambient humidity correction for the particulate concentration ( $P_i$  part), the equation shall be:

$$P_{i\text{corr}} = (P_i)(K_p)$$

$$K_p = 1 / (1 + 0.0133 * (H - 10.71))$$

Where:

$H_a$  = humidity of the intake air, g water per kg dry air

$$H_a = (6.220 * R_a * p_a) / (p_B - p_a - R_a * 10^{-2})$$

$R_a$  = relative humidity of the intake air, %

$p_a$  = saturation vapor pressure of the intake air, kPa

$p_B$  = total barometric pressure, kPa

(iii) When the multiple filter method is used, the following equations shall be used.

(A) Mass of particulate emitted is calculated as follows:

$$PT \text{ gr/hr}_i = \frac{(P_{i\text{corr}} \text{ mg}_i)(m_{\text{mix}} \text{ kg/hr}_i)}{(m_{\text{sample}} \text{ kg}_i)(1000 \text{ mg/gr})}$$

View or download PDF

(B) Determination of weighted particulate average is calculated as follows:



$$PT \text{ gr/hr} = \sum_{i=1}^{i=n} (PT \text{ gr/hr}_i)(WF_i)$$

[View or download PDF](#)

(C) Determination of particulate index for the mass particulate from the average of the test modes shall be calculated as follows:

$$PI = \frac{(PT \text{ gr/hr})(1000 \text{ mg/gr})(1 \text{ hr/60 min})(35.31 \text{ ft}^3/\text{m}^3)}{(1/1 \text{ mg/m}^3)}$$

[View or download PDF](#)

(iv) When the single filter method is used, the following equations shall be used.

(A) Mass of particulate emitted:

$$PT \text{ gr/hr} = \frac{(P_{\text{cor}} \text{ mg})(m \text{ mix kg/hr}) \text{ avg.}}{(m \text{ sample kg})(1000 \text{ mg/gr})}$$

[View or download PDF](#)

Where:

$$(m \text{ mix kg/hr}) \text{ avg.} = \sum_{i=1}^{i=n} (m \text{ mix kg/hr}_i)(WF_i)$$

[View or download PDF](#)

$$(m \text{ sample kg}) = \sum_{i=1}^{i=n} (m \text{ sample kg}_i)$$

[View or download PDF](#)

(B) Determination of particulate index for the mass particulate from the average of the test modes shall be as follows:

$$PI = \frac{(PT \text{ gr/hr})(1000 \text{ mg/gr})(1 \text{ hr/60 min})(35.31 \text{ ft}^3/\text{m}^3)}{(1/1 \text{ mg/m}^3)}$$

[View or download PDF](#)

(v) When the effective weighting factor,  $WF_{E,i}$ , for each mode is calculated for the single filter method, the following shall apply.

$$(A) \quad WF_{E,i} = \frac{(m \text{ sample kg}_i)(m \text{ mix kg/hr avg.})}{(m \text{ sample kg})(m \text{ mix kg/hr}_i)}$$

[View or download PDF](#)

(B) The value of the effective weighting factors shall be within  $\pm 0.005$  (absolute value) of the weighting factors listed in Table E-3.

(b) A particulate index for each requested rated speed and horsepower shall be the value determined in paragraph (a)(9)(iii)(C) of this section for the multiple filter method or paragraph (a)(9)(iv)(B) of this section for the single filter method.

(1) Particulate indices less than 20,000 cfm shall be rounded up to the next 500 cfm. Example: 10,432 cfm shall be listed 10,500 cfm.

(2) Particulate indices greater than 20,000 cfm shall be rounded up to the nearest thousand 1,000 cfm. Example: 26,382 cfm shall be listed 27,000 cfm.

[61 FR 55504, Oct. 25, 1996; 62 FR 34640, June 27, 1997]

[↑ Back to Top](#)

### §7.90 Approval marking.

Each approved diesel engine shall be identified by a legible and permanent approval marking inscribed with the assigned MSHA approval number and securely attached to the diesel engine. The marking shall also contain the following information:

- (a) Ventilation rate.
- (b) Rated power.
- (c) Rated speed.
- (d) High idle.
- (e) Maximum altitude before deration.
- (f) Engine model number.

[↑ Back to Top](#)

#### **§7.91 Post-approval product audit.**

Upon request by MSHA, but no more than once a year except for cause, the approval holder shall make a diesel engine available for audit at no cost to MSHA.

[↑ Back to Top](#)

#### **§7.92 New technology.**

MSHA may approve a diesel engine that incorporates technology for which the requirements of this subpart are not applicable if MSHA determines that the diesel engine is as safe as those which meet the requirements of this subpart.

[↑ Back to Top](#)

---

Need assistance?