



**ATMAE**

LEAD • INNOVATE • COLLABORATE

**STUDY GUIDE**  
**FOR THE**  
**CERTIFIED MANUFACTURING SPECIALIST (CMS)**  
**CERTIFICATION**  
**EXAM**



© 2009-2014 Association of Technology, Management, and Applied Engineering

## **TABLE OF CONTENTS**

Content for the ATMAE Manufacturing Specialist Certification Exam .....	3-5
Sample Questions .....	6-8
References Used for Developing Exam Questions .....	9
Recommendations for Taking the ATMAE Manufacturing Specialist Exam .....	10
Answers to Sample Questions .....	10
ATMAE Certification Examination General Information .....	11
Policy .....	11
Examination Information .....	11
Individual Examinations .....	11
Certification after Examination .....	11
Program Assessment .....	11
Certificates .....	11

## **CONTENT FOR ATMAE MANUFACTURING SPECIALIST CERTIFICATION EXAM**

The 16 major content areas from which the exam is comprised are as follows:

	<b><u>Content</u></b>	<b><u>Number of Questions</u></b>
1.	<b>Manufacturing Joining Processes</b>	<b>10</b>
1.1	Brazing and Soldering	
1.2	Solid State/Resistance Welding	
1.3	Arc/Gas Welding	
1.4	Arc/Gas Cutting	
1.5	Mechanical Fastening	
2.	<b>Manufacturing Forming Processes</b>	<b>10</b>
2.1	Shearing	
2.2	Drawing, Extrusion, and Forging	
2.3	Bending	
2.4	Sheet Metal Classification	
2.5	Sheet Metal Fabrication Nomenclature	
3.	<b>Manufacturing Casting Processes</b>	<b>10</b>
3.1	Casting Nomenclature	
3.2	Expendable-Mold Casting	
3.3	Permanent-Use Casting	
4.	<b>Nontraditional Machining</b>	<b>5</b>
4.1	Chemical	
4.2	Electrical	
4.3	Mechanical	
4.4	Thermal	
5.	<b>Machining</b>	<b>20</b>
5.1	Abrasive	
5.2	Turning	
5.3	Milling	
5.4	Hole Making	
5.5	Thread Manufacturing	
5.6	Gear Manufacturing	
5.7	Miscellaneous Machining Processes	
5.8	Feed, Speed, and Material Removal Rate Calculations	

<u>Content</u>		<u>Number of Questions</u>
6.	Manufacturing Philosophies	5
6.1	Lean	
6.2	Theory of Constraints	
6.3	Benchmarking	
6.4	TQM	
7.	Polymers	10
7.1	Molecular Composition and Properties	
7.2	Types of Plastics	
7.3	Processing Equipment	
7.4	Chemicals and Additives	
7.5	Mold Pressure Calculations	
8.	Industrial Materials	10
8.1	Heat Treatment of Materials	
8.2	Phases of Ferrous Materials	
8.3	Material Classifications and Properties	
8.4	Material Tests	
8.5	Material Strength Terminology	
9.	Computer Integrated Manufacturing	10
9.1	G&M Code Terminology	
9.2	CNC and CAD/CAM Nomenclature	
9.3	Types of Manufacturing Systems	
9.4	Robotics	
10.	Quality	15
10.1	Control Charts	
10.2	Six Sigma Quality & ISO Standards	
10.3	Statistical Concepts	
10.4	Quality Management	
10.5	Diagrams	
11.	Production Planning	10
11.1	Techniques for Process Planning	
11.2	Capacity Planning	
11.3	Master Production Scheduling	
11.4	Inventory Planning and Control	

<u>Content</u>	<u>Number of Questions</u>
12. Wood Technology	10
12.1 Types of Lumber	
12.2 Classification of Lumber	
12.3 Types of Wood Processing Equipment	
12.4 Adhesives	
12.5 Wood Joints	
12.6 Abrasives	
13. Metrology	10
13.1 Standards of Measurement	
13.2 Decimal Equivalency	
13.3 Measuring Instruments and Machines	
13.4 Reading Measuring Instruments	
14. Supervision/Management	20
14.1 Management Concepts and Skills	
14.2 Roles of Managers and Supervisors	
14.3 Functions of Management	
14.4 Communication and Motivation	
14.5 Relationship and Team Building	
14.6 Leadership Styles	
14.7 Appraisal and Discipline	
14.8 Discrimination	
15. Technical Drafting	15
15.1 Multiview Projection	
15.2 Axonometric Projection	
15.3 Oblique Projection	
15.4 Perspective Projection	
15.5 Geometric Dimensioning and Tolerancing	
15.6 Drafting Nomenclature	
15.7 Classification of Fits	
15.8 Sectional Views	
16. Electronics	10
16.1 Electronic Components	
16.2 Electrical Power	
16.3 Electric Motors	
16.4 Circuits, Voltage, Resistance, and Current	

**NOTE:** Individual content mastery data of examinees can be provided for all of the 82 subsections listed under the 16 major content areas for programs using this exam for assessment purposes.

**Sample Questions from Each of the Sections of the Exam**

1. When “stick” welding, which welding current produces the deepest penetration?  
a. AC                                      b. DCRP                                      c. DCSP                                      d. none of these
2. Which welding process is limited to ferrous metals?  
a. Gas Tungsten Arc Welding (GTAW)                                      c. Flux Core Arc Welding (FCAW)  
b. Gas Metal Arc Welding (GMAW)                                      d. Plasma Arc Welding (PAW)
3. Which metal forming process would be used to make solid octagonal bar stock?  
a. plate roll bending                                      c. progressive roll bending  
b. extrusion                                      d. forging
4. Which casting process has a reusable mold and is used for very high production rates of low melting point alloys?  
a. sand                      b. die                      c. no-bake                      d. shell                      e. investment
5. What allows you to see if a mold is filled with molten metal?  
a. gate                      b. runner                      c. riser                      d. sprue                      e. flask
6. Which process is sometimes referred to as YAG?  
a. laser                      b. waterjet                      c. chemical                      d. EDM                      e. photo etching
7. Which NTM process relies on ultraviolet light?  
a. electrochemical      b. chemical                      c. photo etching                      d. laser
8. What is used to cut threads in a hole?  
a. reamer                      b. knurl                      c. tap                      d. die                      e. broach
9. What machining process would be used to make a square hole in steel?  
a. reaming                      b. boring                      c. knurling                      d. drilling                      e. broaching
10. What would be the spindle speed (rpm) for a 1” diameter (8 teeth) side cutter (HSS) cutting mild steel? Recommended cutting speed is 50 sfpm and the feed per tooth is .009”?

**Formulas for Machining Problems:**

CS = cutting speed in sfpm  
rpm = revolutions per minute  
R = feed per tooth per revolution

D = diameter of cutter in inches  
F = feed rate in inches per minute  
T = number of teeth

$$\text{rpm} = \frac{\text{CS} \times 12}{D \times 3.14}$$

$$\text{CS} = \frac{D \times 3.14 \times \text{rpm}}{12}$$

$$F = R \times T \times \text{rpm}$$

- a. .072                      b. 3.6                      c. 13                      d. 24                      e. 191

11. What do we call the practice of when companies bond together economically?  
a. Kaizen      b. Kanban      c. Keiretsu      d. Poka-Yoke      e. Benchmarking

12. Which is computed by dividing the available work time per day by the required number of parts per day?  
a. Kaizen      b. Kanban      c. Keiretsu      d. Theory of Constraints      e. Takt time

13. Which plastic is often mixed with fibers and is used to make spas?  
a. polyamide      b. silicone      c. polyester      d. tetrafluoroethylene      e. acetal

14. Which plastic has the highest strength-to-weight ratio of any material when mixed with graphite?  
a. polyurethane      b. silicone      c. phenolic      d. polyester      e. epoxy

15. Which type of load occurs by pulling or stretching a part from opposite sides?  
a. impact      b. tension      c. compression      d. shear      e. torsion

16. What is the point at which the specimen will no longer return to its original shape?  
a. yield strength      c. yield point      e. proportional limit  
b. elastic limit      d. ultimate tensile strength

17. What kind of unit cell is this?  
a. body-centered cubic  
b. face-centered cubic  
c. close-packed hexagonal  
d. flat-centered cubic  
e. none of these

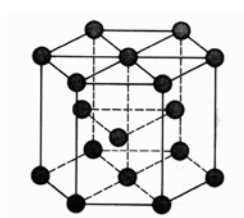

18. What does the G-code G01 tell the CNC machine?  
a. turn on the spindle      c. rapid traverse  
b. change the tool      d. linear interpolation

19. What is the name of this robot?  
a. Cylindrical  
b. Polar  
c. SCARA  
d. Gantry  
e. Articulated

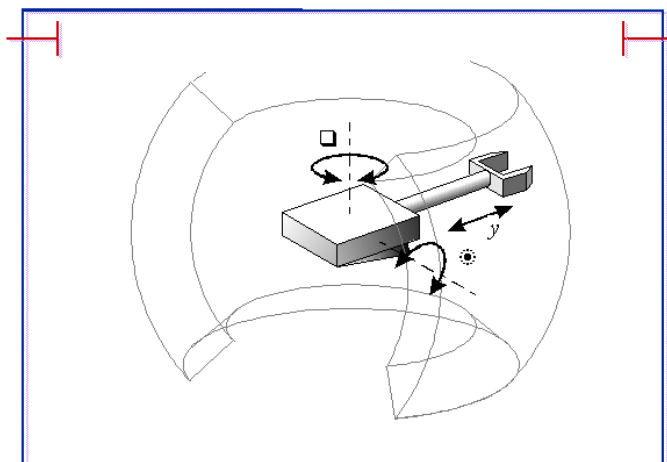

20. Quality characteristics that are classified as conforming or nonconforming to specifications such as a “go/no go gage” applications are referred to as \_\_\_\_\_ data?  
 a. variable                      b. continuous                      c. attribute                      d. either A or C
21. Which one of the following is not correct with respect to the total area under the curve associated with  $\pm 1\sigma$ ,  $\pm 2\sigma$ , and  $\pm 3\sigma$ ?  
 a. 99.73%                      b. 95.46%                      c. 90.34%                      d. 68.26%
22. Variation is present in every process. Which one of the following statements is not true?  
 a. principal sources of variation include equipment, materials, environment, and operator.  
 b. automation has increased the effects of environmental variation.  
 c. equipment variation includes, but is not limited to, tool wear, vibration, and part positioning.  
 d. material variations can occur in both the finished product and raw material.
23. Which of the following is a hardwood?  
 a. maple                      b. pine                      c. redwood                      d. cedar
24. Which type of joint is half the material removed from each piece to be fastened?  
 a. miter                      b. dado                      c. groove                      d. lap
25. How is 1/8” written as a decimal?  
 a. .018”                      b. .0625”                      c. .125”                      d. .625”                      e. .0125”
26. What device allows current to flow in only one direction?  
 a. resistor                      b. coil                      c. capacitor                      d. diode
27. How many watts does a 110 volt circuit use that draws 20 amps?  
 a. 220                      b. 2200                      c. 5.5                      d. .19
28. How much current is required for a 220 volt circuit with a 100 ohm resistor?  
 a. 2.2                      b. .45                      c. 22,000                      d. 100
29. Which type of team is most commonly used in business?  
 a. work                      b. virtual                      c. problem solving                      d. cross functional
30. What is the development and maintenance of sound on-the-job relationships with subordinates, peers, and superiors?  
 a. Respect                      b. Relationship Building                      c. Human Relations                      d. Communication



## **References**

### **MANUFACTURING-RELATED SECTIONS**

- DeGarmo, E. P., Black, J. T., and Kohser, R. A. (2008). *Materials and processes in manufacturing* (10<sup>th</sup> ed.). New York: Macmillan Publishing Co., Inc.
- Kalpakjian, S., Schmid, S. R. (2006). *Manufacturing engineering and technology* (5<sup>th</sup> ed.). Upper Saddle River, NJ: Pearson Prentice Hall, Inc.
- DuVall, J. B., Hillis, D. R. (2008). *Manufacturing processes: Automation, materials, and packaging* (2<sup>nd</sup> ed.). Tinley Park, IL: The Goodheart-Willcox Company, Inc.
- Most manufacturing texts cover this material.

### **PRODUCTION PLANNING**

- Minty, G. (1998). *Production planning and controlling: A problem-based approach*. Tinley Park, IL: The Goodheart-Willcox Company, Inc.

### **SUPERVISION/MANAGEMENT**

- Greer, C. R. and Plunkett, W. R. (2003). *Supervision: Diversity and teams in the workplace*. (11<sup>th</sup>ed.). Upper Saddle River, NJ: Pearson Prentice Hall, Inc.
- Robbins, S. P. (2003). *Organizational Behavior* (10<sup>th</sup> edition). Upper Saddle River, NJ: Pearson Prentice-Hall, Inc.

### **TECHNICAL DRAFTING**

- Brown, W. C., Kicklighter, C. E. (2008). *Drafting and design* (7<sup>th</sup> ed.). Tinley Park, IL: The Goodheart-Willcox Company, Inc.
- Giesecke, F. E. et al. (2002). *Technical Drawing* (12<sup>th</sup> ed.). Upper Saddle River, NJ: Pearson Prentice Hall, Inc.
- Any basic drafting text should cover this material.

### **QUALITY**

- Besterfield, D. H. (2008). *Quality control* (8<sup>th</sup> ed.). Upper Saddle River, NJ: Pearson Prentice-Hall, Inc..
- Aiken, C. Harold. (2006). *Quality: A corporate force managing for excellence*. Upper Saddle River, NJ: Pearson Prentice-Hall, Inc..
- Goetsch, David L. & Stanley B. Davis. (2006). *Quality management: introduction to total quality management for production, processing, and services*. Upper Saddle River, NJ: Pearson Prentice-Hall, Inc.
- Any quality book covering control charts, distributions, and diagrams.

### **COMPUTER INTEGRATED MANUFACTURING**

- Rehg, J. A., Kraebber, H. W. (2005). *Computer-integrated manufacturing* (3<sup>rd</sup> ed.). Upper Saddle River, NJ: Pearson Prentice-Hall, Inc.
- Should know the G and M codes for CNC programming.
- Any robotics text that classifies robots.

### **ELECTRONICS**

- Miller, R., Miller, M. R. (2002). *Electronics the easy way* (4<sup>th</sup> ed.). Hauppauge, NY: Barron's Educational Series, Inc.
- Any basic electronics text should cover this material.

### Recommendations for Taking the ATMAE Exam

- ★ Thoroughly review this Study Guide and review the reference textbooks.
- ★ You do NOT have to pass each section. Only a composite passing score is required.
- ★ Rest well the night before the exam.
- ★ Do NOT leave any questions blank. All questions are multiple choice, so make an educated guess at questions containing content you may not be familiar with.
- ★ Don't panic! You do know this material or your instructor, mentor, or colleague would not want you to take the exam.
- ★ Pace yourself. There are 180 questions and you have 120 minutes (2 hours) to finish.
- ★ Don't spend too much time on one question because all questions are worth the same.
- ★ Flag questions you are unsure of and come back to them at the end if you have time.
- ★ Maintain a positive attitude. You can always retake the exam if you do not pass.

### Answers for Sample Questions

1. b   2. c   3. b   4. b   5. c   6. a   7. c   8. c   9. e   10. e

11. c   12. e   13. c   14. e   15. b   16. b   17. c   18. d   19. b   20. c

21. c   22. b   23. a   24. d   25. c   26. d   27. b   28. a   29. c   30. c

## **ATMAE Certified Manufacturing Specialist Examination General Information**

### **Policy**

The Board of Certification shall design and administer certification examinations for all individuals. The examinations shall be administered online as requested. The areas covered by the examinations and the minimum acceptable scores shall also be determined by the Board of Certification.

### **Examination Information**

The ATMAE Manufacturing Specialist Certification Examination is currently available for use for individual certification and as a program assessment examination. The exam is an open book, **180**-question, multiple choice examination with questions on the following 16 content areas: Manufacturing Joining, Forming, and Casting, Machining, Non Traditional Machining, Polymers, Industrial Materials, Computer Integrated Manufacturing, Production Planning, Quality; Management & Supervision, Metrology, Wood Technology, Technical Drafting, Manufacturing Philosophies, and Electronics.

### **Individual Examinations**

Individuals interested in taking the exam on an individual basis should contact ATMAE to make arrangements. Individuals must pay an examination fee of \$20 to sit for the exam. **If the individual passes and wants to become certified, they will be responsible for submitting an application and paying the appropriate ATMAE membership fee and certification documentation fee.**

### **Certification after Examination**

Examinees who have passed the ATMAE Manufacturing Specialist Certification Examination and who apply for ATMAE Certification will be certified by ATMAE upon receipt of their application and payment of all applicable fees. Examination results are usually available from the ATMAE Office within 30 days of the date examination score sheets have been submitted to ATMAE for scoring. Applicants must be ATMAE members or join ATMAE in order to be certified. **You can become an ATMAE member by simply applying and paying online at [www.atmae.org](http://www.atmae.org) or by calling ATMAE at (630) 433-4514.** If applying for certification after passing the exam, you will need to pay relevant membership fees and indicate on the application form the approximate date of the exam and the location at which you took the exam so that ATMAE can verify your exam results.

### **Program Assessment**

When used for program assessment purposes, the exam fees are typically paid by the Program or Department using the exam. Aggregate exam scores, and comparative score information, are released to the Program or Department contact after the exams have been scored and the examination fee has been paid. For more information about the ATMAE Certification Examination or to obtain scores and determine your ATMAE Membership status before applying for certification, contact ATMAE by phone at **(630) 433-4514** or by email at [ATMAE@ATMAE.org](mailto:ATMAE@ATMAE.org)

### **Certificates**

Certificates appropriate for framing are issued for one-year periods upon initial certification and upon annual renewal. In addition, individuals who passed the certification exam and stay current with all applicable membership and certification dues will be listed on the ATMAE Certification home page for recognition status by employers and colleagues.

***Note: If you are an individual with disabilities and need academic accommodations, please call ATMAE at (630) 433-4514 to make the necessary arrangements for you to take the test.***